

# SNACK ADVENTURE

*Instruction Booklet*



Thanks for selecting  
**Snackventure™**  
Game Pak for  
your

Nintendo Entertainment System®.

# **TABLE OF CONTENTS**

<b>The Story of Snackventure .....</b>	<b>3</b>
<b>Get Control! .....</b>	<b>5</b>
<b>How to Play .....</b>	<b>11</b>
<b>Powerful Allies .....</b>	<b>13</b>
<b>Dangerous Foes! .....</b>	<b>14</b>
<b>Message from the developers .....</b>	<b>19</b>

Mama Jane quickly jotted down a list of groceries for her big family dinner and sent her husband, Little Hector, and the adventurous Uncle Albertrick to the store.

"Just a few things," she lied to them.

But as they strolled through the aisles, they stumbled upon a swirling portal emerging from a shelf. Before they knew it, they were sucked into the vortex and transported to a fantastical realm, a candy land straight out of a dream.

Now, with their list in hand and the clock ticking, Little Hector and Uncle Albertrick must traverse this unknown landscape, as they collect the items they need to make it back home in time for dinner.

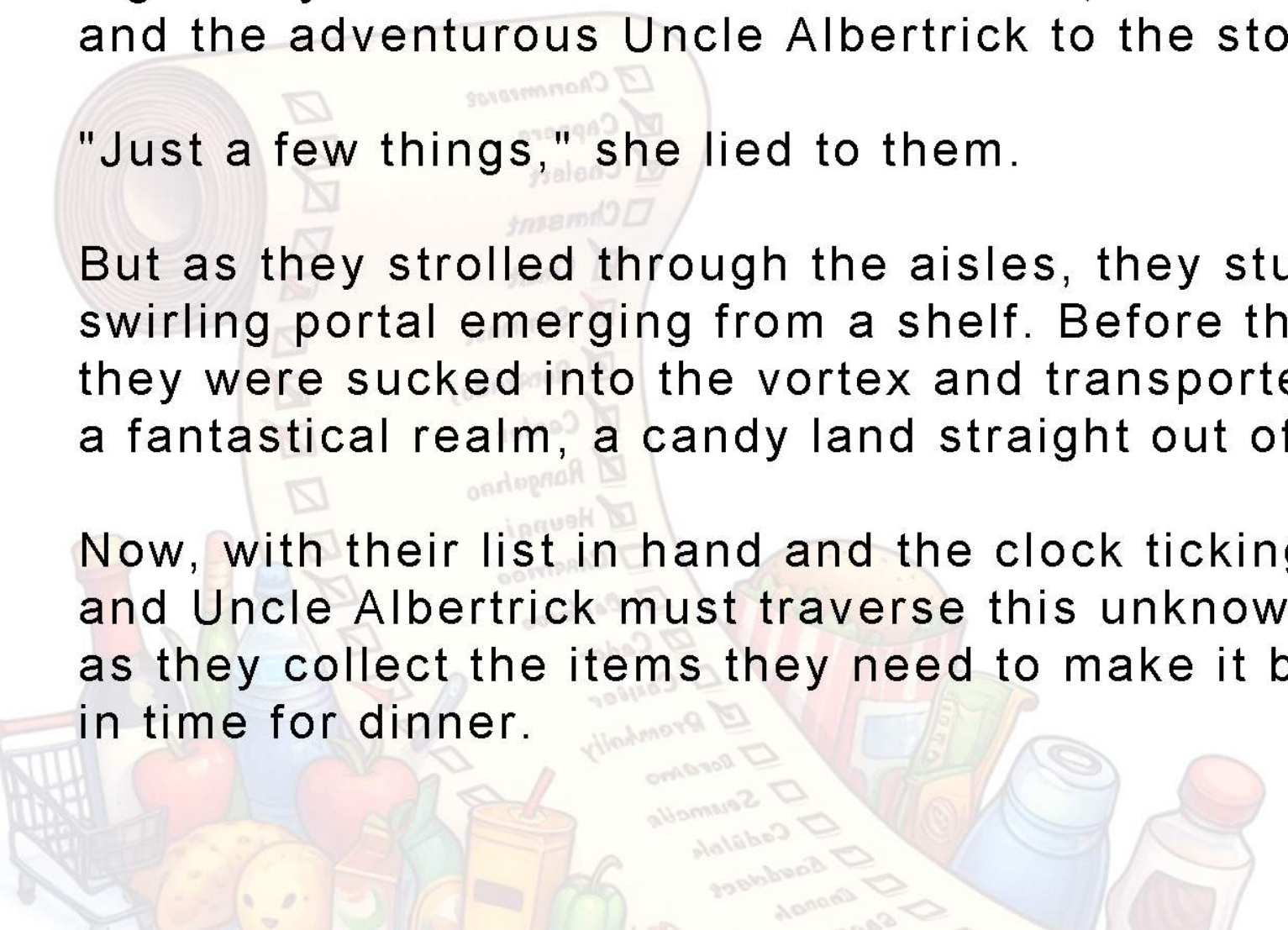



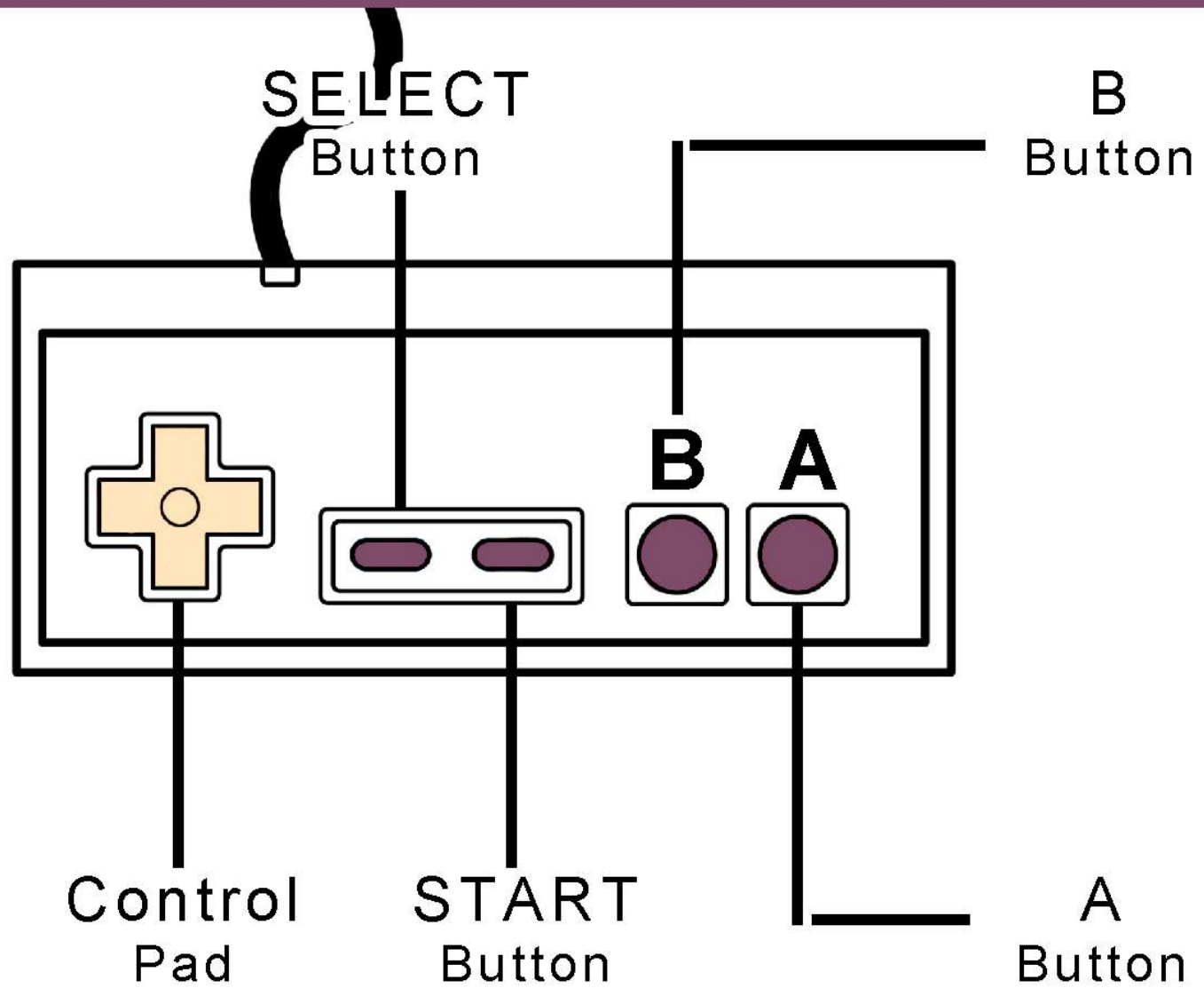



## LEFT and RIGHT

The player  
can **walk** to the left  
and right

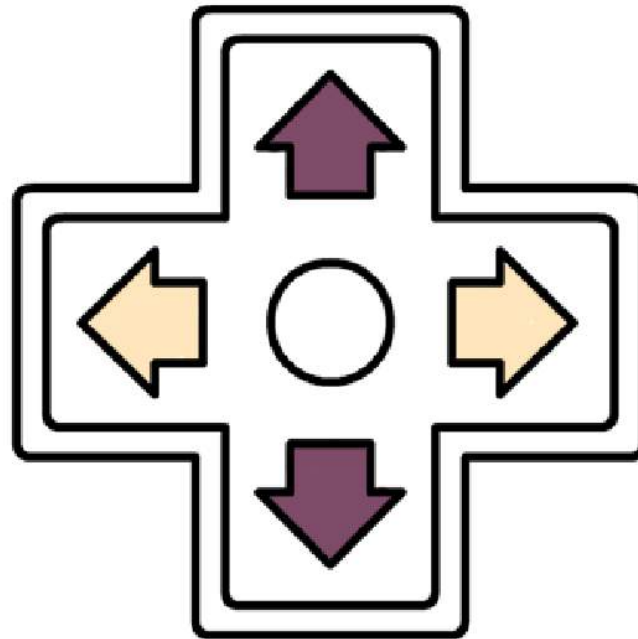

## UP and DOWN

The player  
can **climb** trees  
up and down.



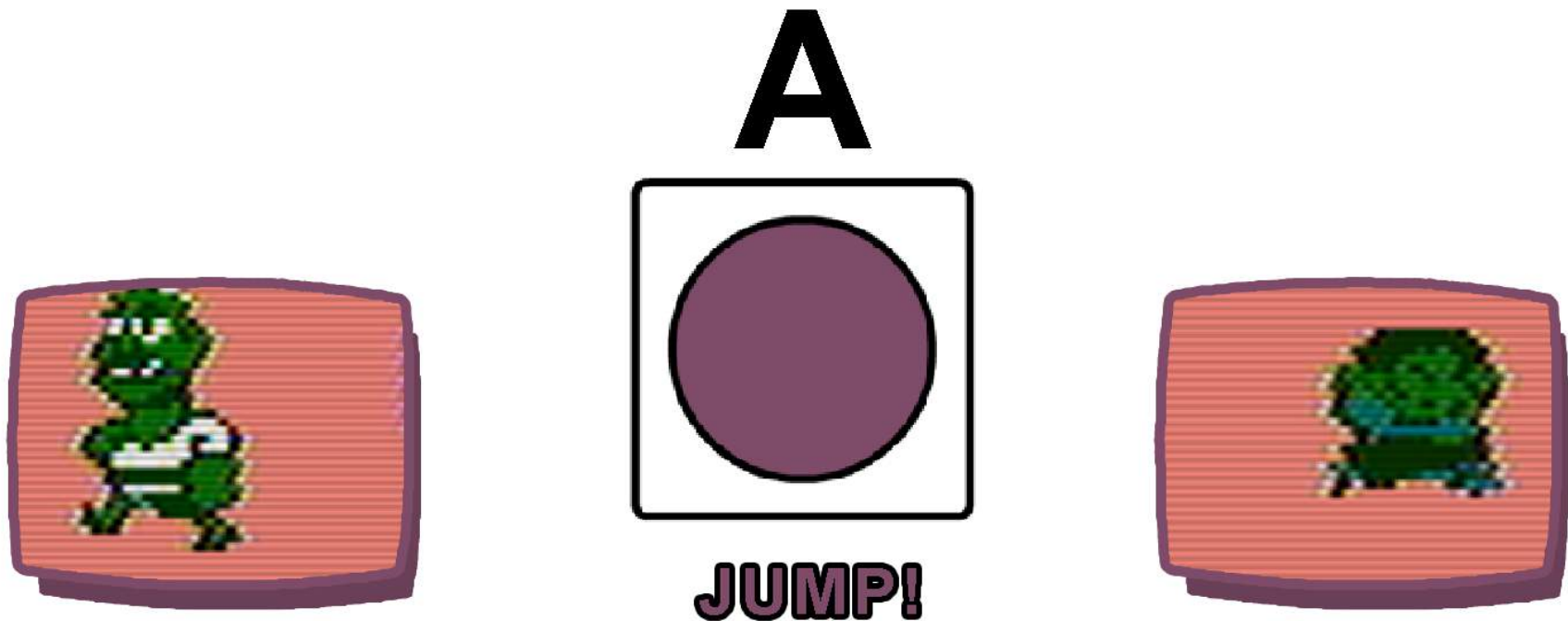

**The player can jump  
from the ground, and trees.**

**The longer you hold the button,  
the higher you will jump.**

# B

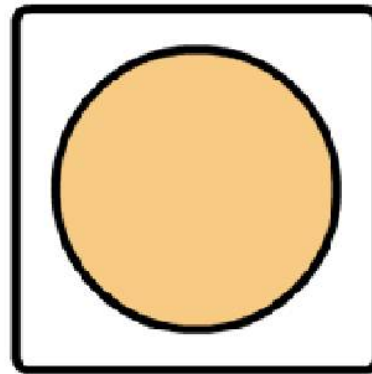
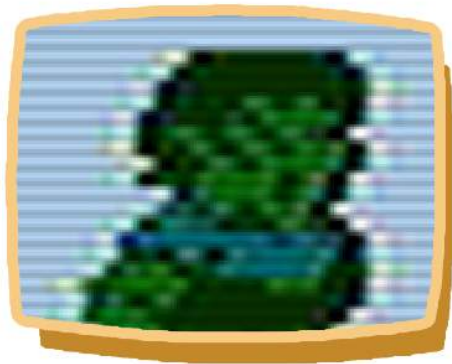

**SHOOT!**

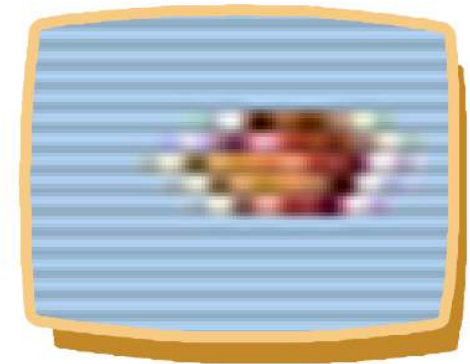

**The player can spit  
the collected peanuts around the land.**

**You can't shoot while climbing.**

## START BUTTON



Menus Screens

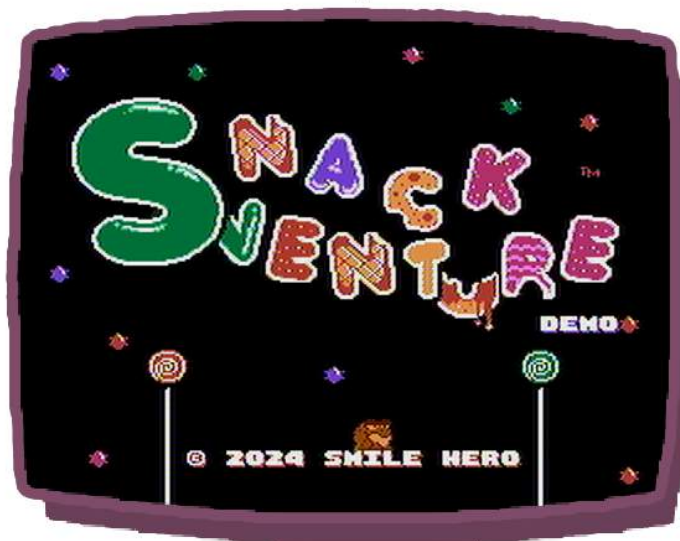

It will Start the Game or Confirm your selection.

Main Game

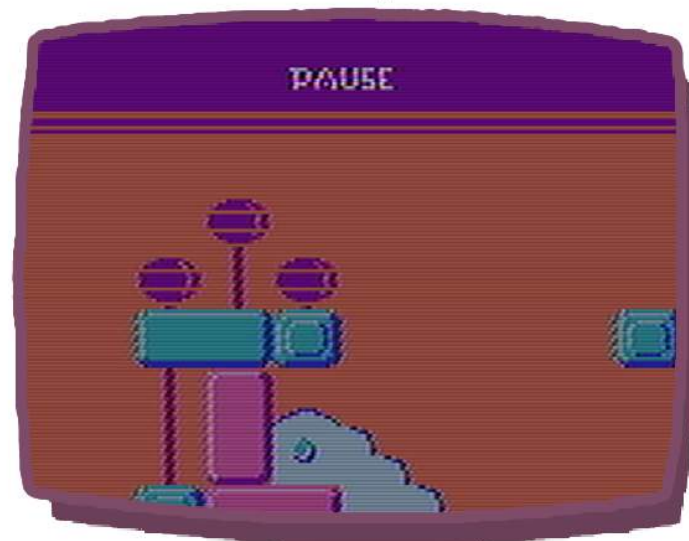

Push the button if you wish to Pause the game. Push it again to Resume.

## SELECT BUTTON



Menu Screens



It will scroll through  
your Options

PAUSE mode



It will bring you to  
an Options Screen.  
You will not be able to go  
back to the Main Game.

As the player goes to the right, the screen follows along. Across this Cotton filled land, you will encounter pits, secrets, and hidden treasures waiting to be discovered. Be aware that you will not be able to return back from where you came, so examine each place carefully!



When coming through the Portal, Little Hector and Albertrick became sick, hence the green color. Be careful, when sick you're more vulnerable to dangers.

Watch out for tricky platforming challenges that will test your reflexes and agility.

You can approach these obstacles with either:

**Little Hector**

Runs slower  
but can get  
into small  
gaps



**Albertrick**

Runs faster  
but can't  
access  
small spaces

Throughout your journey, you'll encounter tasty treats.  
Eat them to gain an advantage!



## The Mystic Muffin

When you're sick, eat these!

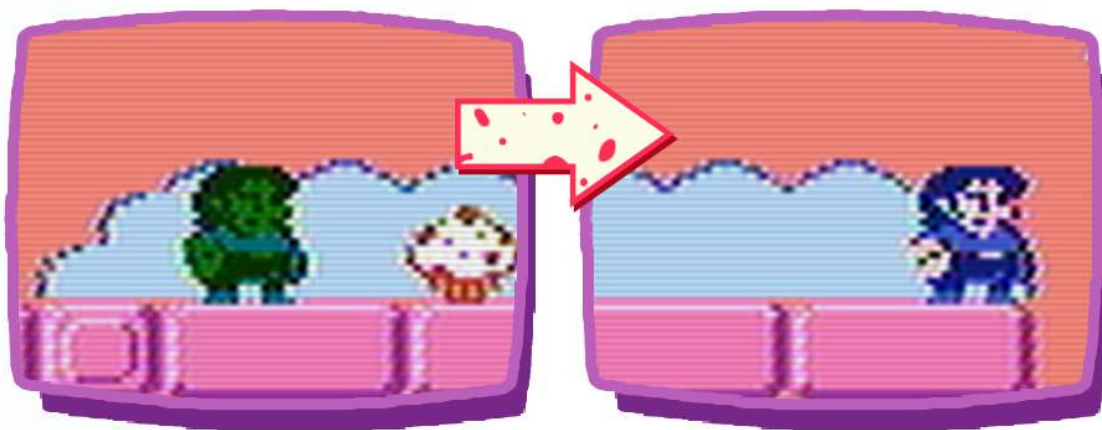



## **Peeble Peanuts**

Collect these and shoot them later!



They're scattered around the land,  
especially in the Cotton Trees.

Not all things are edible,  
moving enemies are food that can make you sick!  
Be careful with them, as you're what you eat!



## **ALFRAJO**

The only strong thing in this one  
is the smell.  
You can shoot it, and also stomp on it...  
just be careful.



# COCOA HOPPER

This frog has really high sugar.  
Spends all day jumping.

Guess it prays to be stopped someday



# CORNELIUS

This little candy corn payed attention to his parents.

He is careful with pits, and is well protected, even after being shot.



# SNAAKY SERPENT

She has fun all day going up and down trees.  
She is made of mint, which protects her  
from anything,  
and its teeth really can rip anyones'  
shoes!



# **A Message from *the* developers:**

This has been a passionate project that has been in the works for several years. There were doubts about making it public, but thanks to the collaboration of wonderful people, this dream has become a reality.

But this doesn't end here...  
the journey of Little Hector and Albertrick is just beginning.  
We will be offering updates periodically,  
so stay tuned!

We apologize for any bugs encountered,  
and we sincerely hope you have enjoyed it.  
THANK YOU VERY MUCH.

**SMILE HERE**

